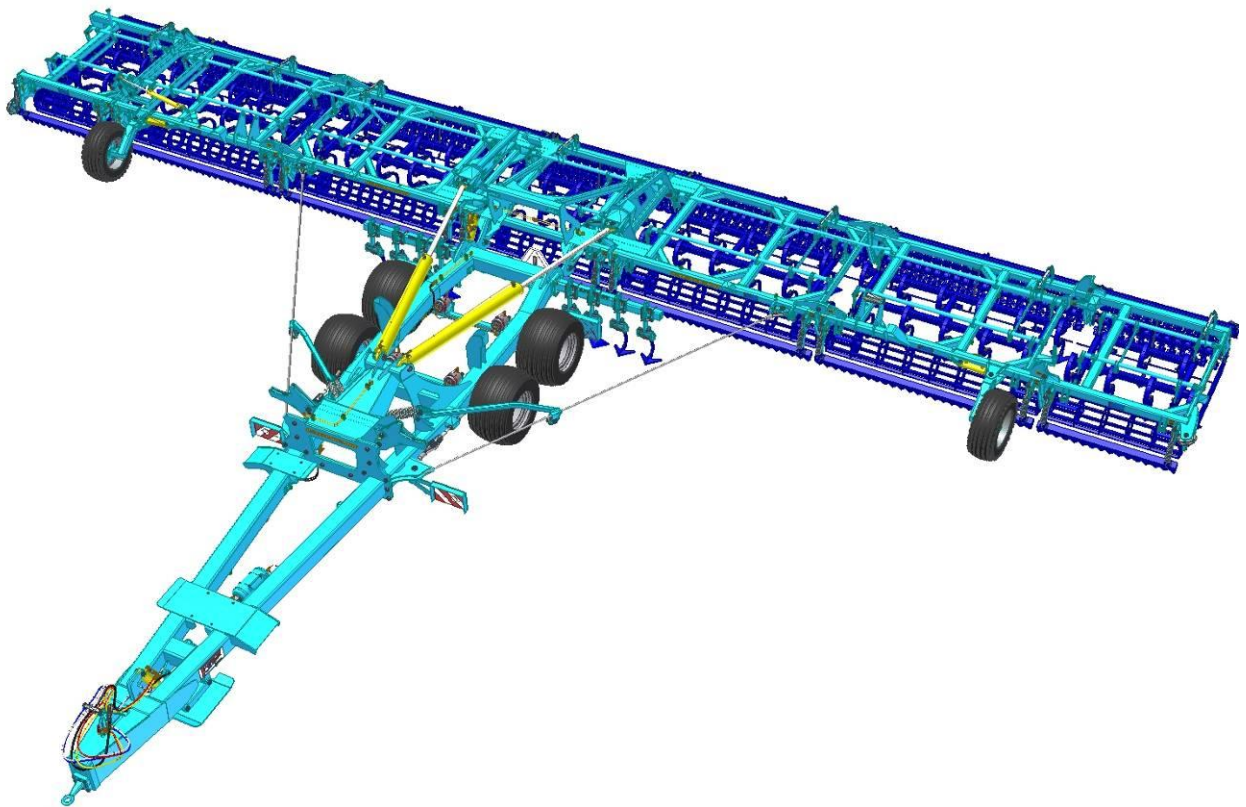


# OPERATING MANUAL

# **KOMPAKTOMAT**

## **K1250PS | K1570PS**



Edition: 4 | effective from: 1. 9. 2014

Dear Customer,

The **K-PS Series** Semi-mounted unfolding Kompaktomates are quality products by Farmet a.s., Česká Skalice, Czech Republic.

You can start to fully use the advantages and qualities of your machine after you have thoroughly studied the Operating manual.

The serial number of the machine is imprinted on the production label and recorded in the Operating manual (see Tabl.1). Please use the serial number whenever you order spare parts in case of a repair. The production label is located on the central frame near the pole.

Use only spare parts for sowing machines according to the **Spare Parts Catalogue** officially published by the producer, the company Farmet a.s. Česká Skalice.

### **Possibilities of Use of Your Machine**

Kompaktomat is intended for presowing preparation of soil as a subsequent operation after ploughing or stubble breaking. The machine is intended for tractors with the output of 243-316 kW (See Chapter **E.3**/Page 5-6). Optimal speed for soil processing is 8-12 km/hour.

Tabl. 1- Characteristics of the machine

<b>TYPE OF MACHINE</b>	
<b>SERIAL NUMBER OF MACHINE</b>	
<b>SPECIAL VERSION OR ACCESSORIES:</b> ..... ..... ..... .....	

## TABLE OF CONTENTS:

- A. LIMITING PARAMETERS	Page 4
- B. TRANSPORTATION	Pages 4-5
- C. LIFTING DEVICE OPERATION	Page 5
- D. ASSEMBLY AT THE CUSTOMER'S PLACE	Page 5
- E. AGGREGATION WITH THE TRACTOR	Pages 5-6
- F. FOLDING AND UNFOLDING THE MACHINE	Page 6
- G. ROAD TRANSPORTATION	Pages 6-7
- H. OPERATING THE MACHINE IN THE FIELD	Page 7
- I. MACHINE ADJUSTMENTS	Page 7
- J. STORAGE	Page 7
- K. MACHINE REPAIRS	Pages 7-8
- L. REPLACEMENT OF WORN-AND-TORN SHARES	Page 8
- M. MACHINE DISPOSAL AFTER ITS SERVICE LIFE	Page 8
- N. LABOUR-PROTECTION STICKERS	Pages 8-11
- 1. MACHINE DESCRIPTION	Page 12
- 1.1 WORKING SECTIONS OF THE MACHINE	Page 12
- 2. SPECIFICATIONS	Page 13
- 3. OPERATIONAL SAFETY RULES	Page 13
- 4. ROAD TRANSPORT RULES	Page 13
- 5. SETTING TO WORK	Page 14
- 6. AGGREGATION WITH THE TRACTOR	Page 15
- 7. PROCEDURE FOR UNFOLDING INTO THE WORKING POSITION	Pages 16-19
- 8. PROCEDURE FOR UNFOLDING INTO THE TRANSPORT POSITION	Pages 19-21
- 9. SETTING THE WORKING TOOLS	Pages 21-23
- 10. FIELD WORK POSSIBILITIES FOR THE MACHINE	Pages 23-24
- 11. BRAKE DISTRIBUTION OF THE MACHINE	Page 25
- 12. EXCHANGING THE WORKING TOOLS	Page 25
- 13. MAINTENANCE AND REPAIRS	Pages 25-26
- 14. LUBRICATION CHART	Page 26
- 15. ENVIRONMENTAL PROTECTION	Page 27
- 16. MACHINE DISPOSAL AFTER ITS SERVICE LIFE	Page 27
- 17. SERVICES AND WARRANTY CONDITIONS	Page 27
- INSTRUCTION MANUAL FOR MACHINE AXLES	Pages 28-32
- LETTER OF GUARANTEE	Page 33
- CE CERTIFICATE OF CONFORMITY	

## **A. LIMITING PARAMETERS**

- A.1** <sup>(1)</sup> Operator(s) may use the machine for agricultural purposes only as an exchangeable implement aggregated with a tractor.
- A.1.1** <sup>(25)</sup> Operator(s) may use the machine only for soil preparation before sowing as a follow-up operation after ploughing or stubble ploughing in the field.
- A.2** <sup>(3)</sup> Operator(s) must not use the machine for other purposes, especially:
- <sup>(4)</sup> Transporting persons on the machine,
  - <sup>(5)</sup> Transporting loads on the machine,
  - <sup>(6)</sup> Aggregating the machine with a towing vehicle other than that mentioned in Chapter E.3.
- A.3** <sup>(7)</sup> The person authorized to work with the machine must:
- <sup>(8)</sup> A person has to be a bearer of the driving licence of the respective category,
  - <sup>(9)</sup> Provably be acquainted with the Operating manual, Labour-protection Rules command must have a good practical command of operating the machine,
  - <sup>(10)</sup> The machine must not be operated by young person(s),
  - <sup>(11)</sup> Know the meaning of the safety signs located on the machine and observe them for safe and reliable machine operation.
- A.4** <sup>(12)</sup> Servicing and maintaining the machine can only be carried out by:
- <sup>(13)</sup> A person authorized by the owner,
  - <sup>(14)</sup> A person trained in agricultural machinery repairs,
  - <sup>(15)</sup> A person provably acquainted with the respective safety rules,
  - <sup>(16)</sup> When repairing the machine coupled with the tractor, a person has to be a bearer of the driving licence of the respective category.
- A.5** <sup>(17)</sup> When operating the machine, the machine operator must ensure safety of other persons.
- A.6** <sup>(18)</sup> When working in the field, the operator is not required to be on the machine. He or she must control the machine from the tractor cab.
- A.7** <sup>(19)</sup> The machine operator may step onto the machine if it is at rest and if the machine is secured against undesirable spontaneous movement for the following reasons only:
- <sup>(21)</sup> Repairs and maintenance,
  - <sup>(xx)</sup> Releasing the side frame connecting rod before unfolding the machine into the working position,
  - <sup>(xx)</sup> Securing the side frame connecting rod after the machine is unfolded into the working position,
  - <sup>(28)</sup> Setting-up the working parts of the machine after unfolding the lateral frames.
- A.8** <sup>(22)</sup> Any changes or adjustments of the machine may only be performed with a written consent of the producer. The producer is not responsible for any potential damages occurred as a result of non-compliance with this instruction. The machine must always be equipped with the prescribed accessories, equipment and gear including the safety labels. All warning and safety signs must be always legible and at their positions. They must be replaced if damaged or lost without delay.
- A.9** <sup>(23)</sup> The Operating manual and the requirements of the safety at work must be always available to the operator.
- A.10** <sup>(24)</sup> When operating the machine, the operator must not consume alcohol, medicine, narcotic and hallucinogenic substances that reduce attention and coordination abilities. If the operator has to take medicine prescribed by the physician or if he or she uses over the counter medicine, he or she must be informed by the physician whether he or she is able to reliably and safely operate the machine under these circumstances.

## **B. TRANSPORTATION**

- B.1** <sup>(1)</sup> The loading capacity of the vehicle, truck or freight car to transport the machine must be at least the same as the weight of the machine. The total weight of the machine is stated on the index plate.

- B.2** <sup>(2)</sup> The dimensions of the machine including the transporting vehicle must meet the respective regulations.
- B.3** <sup>(3)</sup> The transported machine must be fastened to the transporting vehicle carefully and safely to avoid any undesirable and spontaneous loosening.
- B.4** <sup>(4)</sup> The damages incurred by loosening the poorly or incorrectly fastened machine is responsibility of the carrier.
- B.5** <sup>(5)</sup> If transported on another vehicle, the machine must be disassembled.

## **C. LIFTING DEVICE OPERATION**

- C.1** <sup>(1)</sup> The minimum loading capacity of the lifting device and the slinging means intended for manipulation of the machine should be the same as the weight of the machine.
- C.2** <sup>(2)</sup> The machine should be slung in the proper points that are marked with a "chain" sticker if it is to be safely hoisted.
- C.3** <sup>(3)</sup> When the machine to be hoisted is slung in the proper points, it is strictly prohibited to enter.

## **D. ASSEMBLY AT THE CUSTOMER'S PLACE**

- D.1** <sup>(1)</sup> The operator should assemble the machine according to the manufacturer's instructions. Cooperation with a serviceman/technician authorized by the manufacturer is advisable.
- D.2** <sup>(2)</sup> After the assembly is completed, the operator should ensure that all the assembled parts are functional and work smoothly.
- D.3** <sup>(3)</sup> The operator should ensure that handling the machine by using the hoisting mechanism when assembling it is in compliance with Chapter C above.

## **E. AGGREGATION WITH THE TRACTOR**

- E.1** <sup>(1)</sup> The operator must observe all general labour-safety, fire-protection and environmental regulations.
- E.2** <sup>(2)</sup> The operator may hitch up the machine solely to such a tractor that is provided with a rear three-point suspension and a functional undamaged hydraulic system.
- E.3** <sup>(3)</sup> Towing vehicle requirements:

<sup>(5)</sup> Tractor Engine Output Requirements ⇒ for <b>K 1250 PS</b>		<b>243 kW</b>
<sup>(5)</sup> Tractor Engine Output Requirements ⇒ for <b>K 1570 PS</b>		<b>316 kW</b>
<sup>(xx)</sup> Tractor three-point suspension requirements	<sup>(xx)</sup> Ø of the lower hitch bolt	<b>Ø50 mm</b>
	<sup>(xx)</sup> lower hitch height	<b>480 - 550 mm</b>
<sup>(9)</sup> Tractor hydraulic system requirements	<sup>(xx)</sup> side frame unfolding and trail cultivator recess control circuit	<b>The pressure in the circuit: 200 bar, two ISO 12.5 quick coupler sockets</b>
	<sup>(xx)</sup> catch and tracing wheel control circuit	<b>The pressure in the circuit: 200 bar, two ISO 12.5 quick coupler sockets</b>
	<sup>(xx)</sup> supporting leg control circuit	<b>The pressure in the circuit: 200 bar, two ISO 12.5 quick coupler sockets</b>
	<sup>(xx)</sup> K 1570 PS side frame unfolding circuit	<b>The pressure in the circuit: 200 bar, two ISO 12.5 quick coupler sockets</b>

(12) Tractor air system requirements	(13) The machine axle brake circuit	(16) <b>The pressure in the circuit: min.6 bar – max. 8 bar, one single-circuit brake coupling head</b>
--------------------------------------	-------------------------------------	---

- E.4** <sup>(xx)</sup> Before aggregating the machine with the tractor (especially with those not provided with a quick suspension device), the operator must secure the tractor against undesirable movement. Especially with tractors not provided with a quick suspension device, the operator should arrange for another trained person to cooperate. Such a person must not step into the suspension area before the tractor is secured against undesirable movement. With tractors provided with a quick suspension device, this operation can be made by the operator from the tractor driver's seat.
- E.5** <sup>(17)</sup> Aggregating the hydraulic system of the machine with the hydraulic system of the tractor should be performed according to Chapter **5.3** (Page 14) of this Operating manual.

## **F. FOLDING AND UNFOLDING THE MACHINE**

- F.1** <sup>(xx)</sup> Operator(s) must ensure that no person or animal is within the reach of the lateral frames when folding and/or unfolding them. Nobody should insert the fingers into the joint space.
- F.2** <sup>(xx)</sup> Before unlocking the connecting rod, the operator(s) must secure the set against undesirable motion and check (from the tractor cab) by using the hydraulic system control levers whether or not there is oil in the piston rods. Only after the operator is sure that there is oil in the piston rod, may he proceed to unlocking the connection rod.

## **G. ROAD TRANSPORTATION**

- G.1** <sup>(1)</sup> The transportation speed of the tractor with the machine should not exceed the maximum transport speed and the maximum slope accessibility indicated.
- G.2** <sup>(2)</sup> When transported on public roads, increased guardedness should be observed due to the machine dimensions.
- G.3** <sup>(4)</sup> When transporting on public roads the machine should be provided with a functional set of warning lights that must be on. If possible, the highest point of the set (usually the tractor roof) should be provided with a yellow flashing beacon. Moreover, the machine should be provided with the "maximum-speed" sign, with red-and-white-hatched boards at the machine contours and with rear reflectors and reflecting board according to the respective regulations.
- G.4** <sup>(5)</sup> Using international highways and 1st-class highways for transportation of the machine towed by a tractor is prohibited. These may be only crossed.
- G.5** <sup>(6)</sup> The machine should not be transported at poor visibility.
- G.6** <sup>(7)</sup> Note that the driving properties of the set change when towed by a tractor on the road due to different axle loads. Please have this in mind when transporting the machine. The respective road-transport rules should be strictly observed.
- G.7** <sup>(8)</sup> The operator is obliged to produce the respective certificate of roadworthiness (the MOT Certificate) if necessary.
- G.8** <sup>(9)</sup> When transporting the machine on public roads, all the respective traffic rules and traffic signs should be observed.
- G.9** <sup>(10)</sup> When making U-turns or driving reverse gear, be especially careful. Ensure a good outlook from the tractor cab and use another (instructed and authorized) person if necessary.
- G.10** <sup>(11)</sup> When transporting the machine off public roads, operator(s) should not exceed the lowest maximum transport speed and the lowest maximum slope accessibility indicated wherever on the set.

- G.11** <sup>(xx)</sup> The operator must secure the folded side frames by the connecting rod to prevent their unfolding before the start of transportation on ground communications.

## **H. OPERATING THE MACHINE IN THE FIELD**

- H.1** <sup>(1)</sup> The operator should acquaint himself with the machine controls before the first use of the machine.
- H.2** <sup>(2)</sup> Before setting the machine to work, please read the Instructions for use carefully. Pay attention to labour protection, safe operation and transportation, environmental protection, setting the machine and its maintenance.
- H.3** <sup>(3)</sup> The operator is responsible for all damages incurred by improper operation of the tractor and the coupled machine.
- H.4** <sup>(4)</sup> When operating the machine, the operator is obliged to observe all the technical and safety regulation set by the manufacturer.
- H.5** <sup>(5)</sup> When turning the machine at the headland, the machine working tools should be lifted.
- H.6** <sup>(6)</sup> When operating the machine, the operator should observe the prescribed working depths and speeds given in Chapter 2/Page 13 of this Instructions.
- H.7** <sup>(7)</sup> When leaving the tractor cab, the operator is obliged to lower the machine onto the ground and secure it against undesirable motion.

## **I. MACHINE ADJUSTMENTS**

- I.1** <sup>(1)</sup> When adjusting the working tools of the machine, the operator should follow the values recommended in Chapter 9/Pages 20 to 21. Please observe the labour safety principles.
- I.2** <sup>(2)</sup> The machine working tools may be adjusted at rest only with the machine secured against undesirable motion.
- I.3** <sup>(3)</sup> Working tools adjustments should be done on a flat and paved surface so that the soil cultivation is performed evenly.

## **J. STORAGE**

- J.1** <sup>(1)</sup> Before storing the machine, the machine should be thoroughly cleaned and preserved in such a manner that no damage can occur. Special attention should be paid to all the lubrication points indicated. These points should be lubricated thoroughly according to the Lubrication Chart.
- J.2** <sup>(xx)</sup> It is recommended to store the machine in the transport position, i.e. the side frames folded and secured by the connecting rod and the machine resting on the supporting leg. The operator must secure the stored machine from spontaneous movement by activating the hand brake of the machine.
- J.3** <sup>(3)</sup> The operator is obliged to secure the storage place against unauthorized persons' entrance.

## **K. MACHINE REPAIRS**

- K.1** <sup>(1)</sup> Servicing and maintaining the machine can only be carried out by qualified persons duly authorized by the operator, see Chapter A.4
- K.2** <sup>(2)</sup> Any machine repairs may only be made at rest, i.e. the machine does not work. If it is necessary for the machine to be coupled with the tractor during the repair, the ignition key must be removed from the switchbox.
- K.3** <sup>(5)</sup> All kinds of the machine hydraulic circuit repairs may only be made under the following conditions:
- <sup>(6)</sup> The lateral frames are unfolded,



- <sup>(7)</sup> The machine must rest on the shares and rollers;
- <sup>(8)</sup> The machine must be secured against undesirable motion;
- <sup>(9)</sup> The machine hydraulic circuit must be disconnected from the tractor hydraulic circuit;
- <sup>(10)</sup> The machine vicinity must be protected from being contaminated by hydraulic oil;
- <sup>(11)</sup> The machine must not rest on the axle.

**K.4** <sup>(3)</sup> Any machine repairs should be made in service shops.

**K.5** <sup>(12)</sup> Before repairing the machine hydraulic circuits, the repairman must eliminate pressure in the hydraulic circuits with the control levers in the tractor cab. This should be done by moving the levers to their extreme positions back and forth (approx. five times) with the tractor engine stopped.

**K.6** <sup>(4)</sup> When handling the machine with a lifting device, the regulations set forth in Chapter C should be strictly observed.

## **L. REPLACEMENT OF WORN-AND-TORN SHARES**

**L.1** <sup>(xx)</sup> The operator or the serviceman must observe generally valid safety regulations during any replacement of working bodies.

**L.2** <sup>(1)</sup> The shares should be replaced by the serviceman or operator on a flat and paved surface only.

**L.3** <sup>(2)</sup> When replacing the shares, the machine must be aggregated with the tractor according to Chapter E. When replacing the shares, the tractor engine must be stopped and the tractor cab secured against unauthorized entrance or operation.

**L.4** <sup>(5)</sup> If there is a leakage from the tractor hydraulic system, the repairing person is obliged to support the machine shaft mechanically.

## **M. MACHINE DISPOSAL AFTER ITS SERVICE LIFE**

**M.1** <sup>(xx)</sup> The owner shall observe generally valid safety regulations in case of any disposal.

**M.2** <sup>(1)</sup> The operator must ensure that the machine is secured against undesirable motion before starting the disposal operations.

**M.3** <sup>(2)</sup> The operator must ensure that metal parts are separated from those parts that contain hydraulic oil or grease.

**M.4** <sup>(3)</sup> Steel parts must be cut up and delivered to the respective salvage point. The other secondary raw materials should be disposed according to the applicable waste management regulations.

**M.5** <sup>(4)</sup> The operator should ensure that handling the machine with the lifting device is in compliance with Chapter C.

**M.5** <sup>(5)</sup> Before disposing the machine hydraulic circuits, the repairman must eliminate pressure in the hydraulic circuits with the control levers in the tractor cab. This should be done by moving the levers to their extreme positions back and forth (approx. five times) with the tractor engine stopped.

## **N. LABOUR-PROTECTION STICKERS**

**The labour-protection stickers protect operators.**


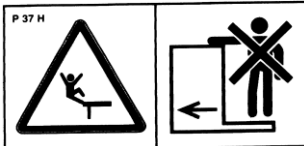


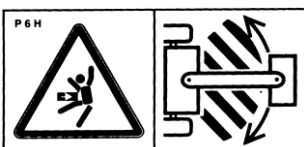

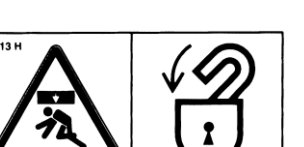

**Generally:**

- A) Strictly adhere to the labour-protection stickers instructions.
- B) All the labour-protection stickers instructions apply to other users as well.
- C) In case of damaging or destroying a **labour-protection sticker** located on the machine, operators are obliged to **replace it or provide the machine with a new one immediately.**

The position, design and exact meaning of the labour-protection stickers located on the machine are given in the following table (Tabl. 2) and in Figure 1.

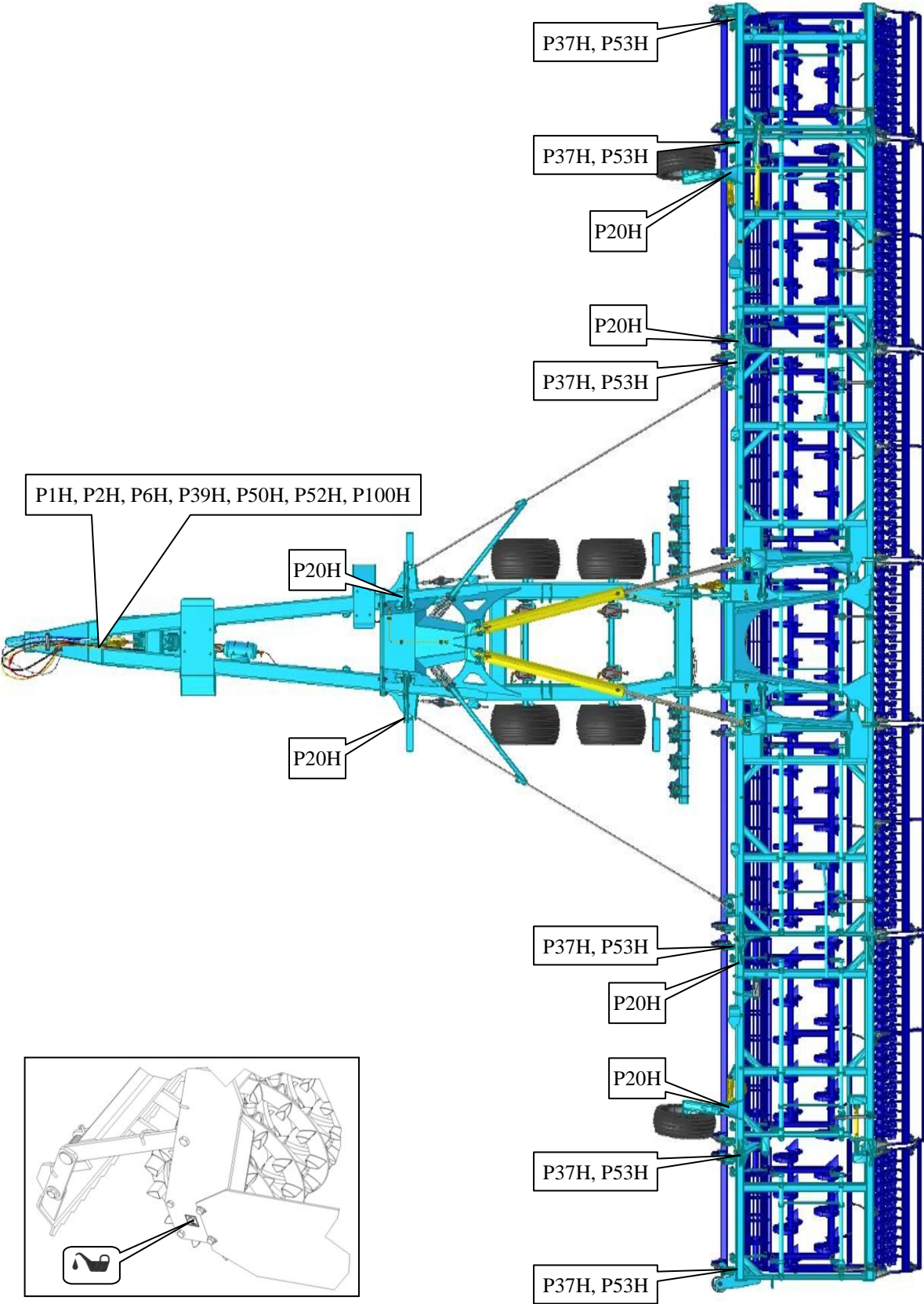


Table 2 - The Labour-protection stickers located on the machine

GRAPHIC DESIGN	DESCRIPTION	LOCATION ON THE MACHINE
	<p>Read carefully the Operating manual before manipulation with the machine. Observe the instructions and safety rules when operating the machine.</p>	<p><b>P 1 H</b></p>
	<p>Driving the machine and transportation on its construction is strictly forbidden.</p>	<p><b>P 37 H</b></p>
	<p>When connecting and disconnecting, do not enter the area between the tractor and the machine. Do not enter that area unless the tractor and the machine are not moving and the engine is off.</p>	<p><b>P 2 H</b></p>
	<p>When opening and closing the side frames and service bridge, stay beyond their reach.</p>	<p><b>P 50 H</b></p>
	<p>Stay beyond reach of the set Tractor – Agricultural Machine when the tractor engine is running.</p>	<p><b>P 6 H</b></p>
	<p>When unfolding the side frames into the transport position, do not reach into the area of contact with the central frame.</p>	<p><b>P 20 H</b></p>
	<p>Secure the axle of the machine against an unexpected drop before its transportation.</p>	<p><b>P 13 H</b></p>
	<p>When working with the machine as well as during its transportation, keep a safe distance from electric appliances.</p>	<p><b>P 39 H</b></p>

	<p>Secure the machine from undesirable movement by activating the hand brake.</p>	<p><b>P 52 H</b></p>
	<p>Do not approach the rotary parts of the machine unless they are standing still, i.e. they are not rotating.</p>	<p><b>P 53 H</b></p>
	<p>It is forbidden to fold and unfold the side frames of the machine on the slope or oblique surface.</p>	<p><b>P 100 H</b></p>
	<p>Lubrication of house bearings.</p>	

Fig.1 – The Labour-protection stickers located on the K 1250 PS, K 1570 PS



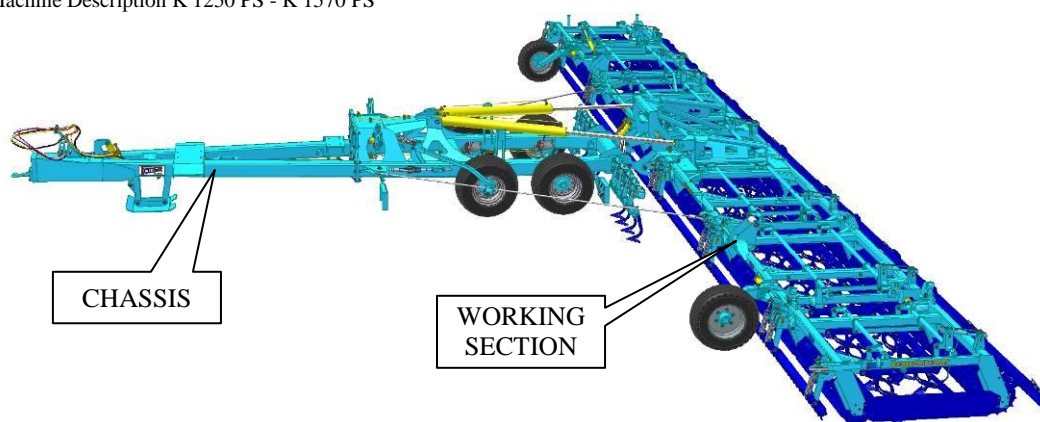
## 1. MACHINE DESCRIPTION

The machine has been designed as semi-mounted and folding. The basic version of the machine includes a chassis and drawn working sections. The machine is structurally designed so that the transport width is up to 3 m and the transport height is up to 3.5 m.

The chassis with the drawn appliance aggregates with a height-adjustable hole for a tractive bolt with  $\varnothing 50$  mm. The chassis includes a supporting leg that supports the machine when it is disconnected from the tractor and there are two firm delayed axles, out of which one is equipped with an automatic parking brake function. Furthermore, the chassis includes hydraulically controlled catches securing the side frames in the transport position. The chassis also includes automatically spring-loaded trail cultivators.

The working section is attached to the chassis by swinging segments that allow continuous height tracing of the field behind the tractor and chassis. Furthermore, the working section is connected to the chassis by main piston rods and tractive ropes that transfer the tractive force from the tractor to the machine during the work in the field. The working section of the machine consists of a massive spring-loaded, height-adjustable variable leveller, crumbling front rollers, height-adjustable ploughshare section with a leveller and compactors with a rear leveller. Furthermore, the working section includes auxiliary wheels that are used for unfolding the machine into the working position or folding it into the transport position.

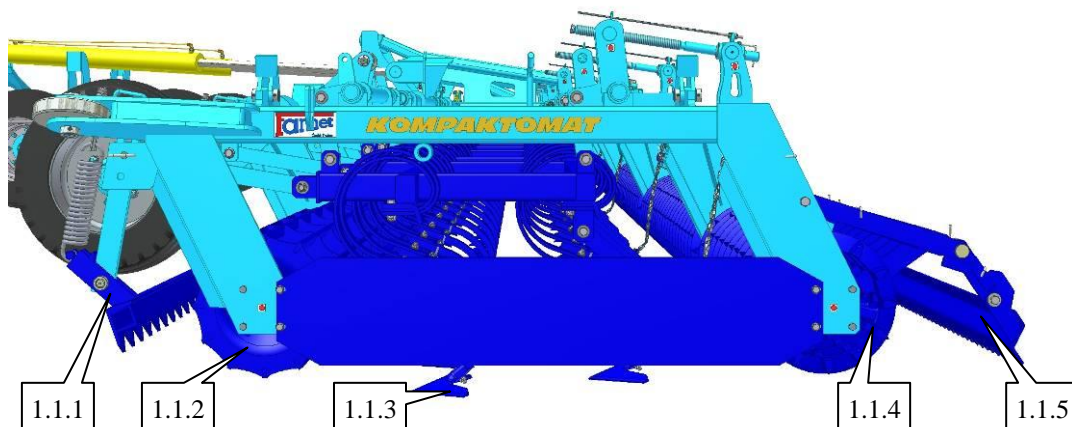
Fig. 2 - Machine Description K 1250 PS - K 1570 PS



### 1.1 WORKING SECTIONS OF THE MACHINE

- 1.1.1 Spring-loaded front drag
- 1.1.2 Front bar roller 400 mm in diameter
- 1.1.3 Share section
  - 1.1.3.1 Duckfoot shares in two rows with a levelling bar
  - 1.1.3.2 Chisel-shaped shares in four rows
- 1.1.4 Rear roller
  - 1.1.4.1 Bar roller (400mm in diameter)
  - 1.1.4.2 Crosskill roller (400mm in diameter) with a cleaner
- 1.1.5 Rear drag

Fig.3 – working tools of the machine



## 2. SPECIFICATIONS

Table 3 - Specifications

PARAMETERS	K 1250 PS	K 1570 PS
Operating Width (mm)	12500	15700
Transport Width (mm)	3000	
Transport height (mm)	3500	
Transport height (mm)	9550	
Operating height (mm)	11550	
Operating Depth (mm)	0-100	
Number of Shares ARROW	53	67
Working capacity (ha/h)	10-15	12,4-18,5
Working speed (km/h)	8-12	
Maximum transport speed (km/h)	243	316
Maximum slope accessibility (°)	25	
Tyre – transport dimension (type)	6	
Tyre pressure (kPa)	19.0/45-17 14PR	
Max. weight of the machine (ver. II)	400	
Working capacity (ha/h)	10500	12500

## 3. OPERATIONAL SAFETY RULES

- 3.1 Before you take over the machine, please check that it has not been damaged during transportation and that all its parts have been supplied according to the delivery note.
- 3.2 Before setting the machine to work, please read these Operating manual carefully.
- 3.3 Before starting to work, please acquaint yourself with the overall functioning of the machine and its controls.
- 3.4 Please observe not only the rules of these Manual but also general labour-protection, fire-protection and environment-protection regulations as well as transportation safety rules.
- 3.5 The machine may only be operated by a person, which meets requirements of the item **A.3** above.
- 3.6 Before setting the machine to work, please check its condition. In case of showing any signs of damaging, the machine must not be operated.
- 3.7 When aggregating the machine with the tractor, follow the Instruction given in Chapter **E**/Page 5 to 6.
- 3.8 Execute aggregation of the machine with the tractor on an even and compact surface.
- 3.9 Before uncoupling the tractor and the machine in the transport position, the machine must be secured against accidental and undesirable unfolding, i.e. the folded lateral frames must be locked by the connecting bar.
- 3.10 When working on slopes, observe the slope accessibility of the whole **TRACTOR-MACHINE** set.
- 3.11 It is strictly forbidden to unfold or fold the machine on slopes – see the **P100H** labour-protection (safety) sticker located on the machine.
- 3.12 Before starting up the tractor, check that there is no unauthorized person within the operating reach of the set and sound the horn.
- 3.13 Operators should pay attention to any person's not approaching the machine during operation in the field.
- 3.14 It is forbidden to dismantle the parts of the machine hydraulic system that are under pressure.
- 3.15 Hydraulic oil penetrating the skin under high pressure causes serious injuries. Should this happens, call the doctor immediately.

## 4. ROAD TRANSPORT RULES

- 4.1 The transport speed of the tractor with the machine should not exceed **25 km p.h.**
- 4.2 When transporting the machine on public roads, follow the instruction given in Chapter **G**/Page 6-7.
- 4.3 When transporting the machine on roads, the operator(s) should observe the applicable law and regulations including those which specify the tractor axle load depending on the transport speed.
- 4.4 When transporting the machine on ground communications, the side frames must be secured by the connecting rod and the machine must be fitted with safety shields with a functional light set.
- 4.5 Considering the size of the machine, the operator transporting the machine must be very careful and considerate to other road users.



## 5. SETTING TO WORK

5.1 When aggregating the machine with the tractor and setting it to work, the steps given in Chapter E, F /Page 5 to 6 should be followed.

5.2 Aggregate the machine with a tractor with the use of the bottom hitch with a  $\varnothing$  50 mm or  $\varnothing$  70 mm bolt or with K80 tow ball.

5.3 Place the trail cultivators on the chassis so that they cultivate the compacted layer of soil made by the tyres of the chassis and the tractor. The range of the position of cultivators may be selected even for tractors with a pair assembly, i.e. up to the width of 3.9 m. The maximal recess of cultivators is 60 mm below the level of the tractor wheel trail.

5.4 To interconnect the hydraulic systems, use the quick-couplers of the identical model (the socket on the machine and the plug on the tractor) - the machine is normally provided with the ISO 12.5 quick couplers.

5.5 Always fold and unfold the machines on a flat surface. Or meet the requirement of the P100H safety label (see p. 10).

5.6 Attach the hoses of the individual hydraulic circuits to the tractor in the order in which the hoses are labelled. The hydraulic circuits are designated with coloured rings (see Fig. 4).

Fig.4-designation of the hydraulic circuits

OZNAČENÍ HYDRAULICKÝCH OKRUHŮ  
DESIGNATION OF HYDRAULIC CIRCUITS  
BEZEICHNUNG VON HYDRAULIKANLAGEN  
НАЗНАЧЕНИЕ ГИДРАВЛИЧЕСКИХ КОНТУРОВ  
DÉSIGNATION DES LIGNES HYDRAULIQUES

**K1250PS=A+B+C+E / K1570PS=A+B+C+D+E**

A.	B.	C.	D.
A.	B.	C.	D.


m11689


**CIRCUIT A** – the circuit for folding and unfolding side frames. Hydraulic circuit designated with **RED** rings. **This hydraulic circuit must always be turned on when working in the field.**

 **DRAWING-OUT PISTON = UNFOLDING INTO THE WORKING POSITION**  
The side frames are unfolded into the working position when this circuit branch is pressurised.

 **PISTON RETRACTION = FOLDING INTO THE TRANSPORT POSITION**  
The side frames are folded into the transport position when this circuit branch is pressurised


**CIRCUIT B** – the circuit for the control of transportation bolts together with auxiliary wheels. Hydraulic circuit designated with **WHITE** rings. **This hydraulic circuit does not need to be turned on when working in the field.**

 **DRAWING-OUT PISTON = FOLDING INTO THE TRANSPORT POSITION**  
By pressurising this circuit branch, the bolts lift the side frames into the transport position and the auxiliary wheels are folded to the frames into the transport position when the side frames have been lifted.

 **PISTON RETRACTION = UNFOLDING INTO THE WORKING POSITION**  
By pressurising this circuit branch, the auxiliary wheels are unfolded from the frames. Once unfolded, the bolts start to open and lower the side frames.

**CIRCUIT C** – the circuit for the control of the supporting leg of the chassis. Hydraulic circuit designated by **BLACK** rings. **This hydraulic circuit does not need to be turned on when working in the field.**


 **DRAWING-OUT PISTON = SETTING THE TRANSPORT POSITION**  
The supporting leg stands on the ground when this circuit branch is pressurised.


 **PISTON RETRACTION = SETTING THE WORKING POSITION**  
The supporting leg is lifted from the ground when this circuit branch is pressurised.

**CIRCUIT E** – the circuit for controlling the position of the track cultivators behind the chassis wheels. Hydraulic circuit designated by **MULTI-COLOUR** rings. **This hydraulic circuit must always be turned on when working in the field.**




*Attention! Do not manipulate with this circuit when the machine is standing on hard surface (asphalt, concrete) as it could damage the track cultivators or the surface.*

 **DRAWING-OUT PISTON = SETTING THE WORKING POSITION**  
Hydraulic circuit designated by a **YELLOW + GREEN** ring. The track cultivators are set into the working position when this circuit branch is pressurised.

 **PISTON RETRACTION = SETTING THE TRANSPORT POSITION**  
Hydraulic circuit designated by a **RED + BLUE** ring. The track cultivators are set into the transport position when this circuit branch is pressurised.

**CIRCUIT D** – the circuit for folding and unfolding the external 1.5m side frames. Hydraulic circuit designated by **YELLOW** rings. This hydraulic circuit is only installed in K1570PS.

**This hydraulic circuit does not need to be turned on when working in the field.**

 **UNFOLDING SIDE 1.5m FRAMES INTO THE WORKING POSITION**  
The external side frames are open into the working position when this circuit branch is pressurised.

 **FOLDING SIDE 1.5m FRAMES INTO THE TRANSPORT POSITION**  
The external side frames are open into the transport position when this circuit branch is pressurised.

## 6. AGGREGATION WITH THE TRACTOR

- For safe aggregation, observe the regulations given in Chapter E / Page 5 to 6.
- Only aggregate the machine with a tractor in the lower hitch with a  $\varnothing$  50 mm or  $\varnothing$ 70 mm bolt or in K80 tow ball, even when the machine is just being transported (see Fig.5).
- The machine may only be aggregated with a tractor with an output intended for such use according to Chapter No. 2.
- As additional load to the tractor (counterweight) only the weights prescribed by the manufacturer should be used.
- Only aggregate the machine with a tractor equipped with single-circuit two-hose brakes.



Fig. 5 – Connecting the machine with the lower tractor hitch



## 7. PROCEDURE FOR UNFOLDING INTO THE WORKING POSITION

	K1250PS	K1570PS
	1.	1.
2.	2.	

**7.1** It is necessary to connect the machine with the lower hitch of the tractor with a  $\varnothing 50$  mm bolt for safe unfolding and folding. When handling and unfolding the machine, the tractor hitch is loaded with vertical force of 25 kN up and 35 kN down!!! Thus the tractor hitch must meet this requirement!

Fig.6 – Illustration of the load of the lower tractor hitch during folding and unfolding

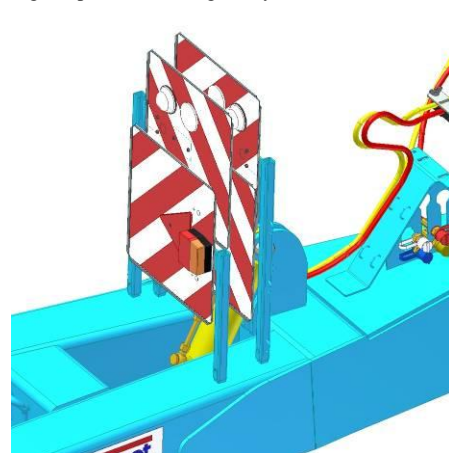


**7.2** Prior to unfolding, dismantle the warning shields and attach them to the hangers on the pole. Fold and unfold the machine on a sufficiently large and even area. If you are standing on a slight slope, place the machine set so that it is oriented up the slope in the driving direction. When folding, the tractor and the machine must be locked and the movement of the set must be prevented!

Fig.7 - K 1570 PS prior to unfolding



Fig.8 – place for storing safety shields



### 7.3 UNFOLDING THE MACHINE – PHASE 1 – WHEELS AND CATCHES



Start unfolding by **Circuit B = pressurise the circuit branch designated by two white rings**. Firstly, the side wheels will unfold and then the catches will open and the side frames will apply a load on the auxiliary wheels. **Warning: to make the wheels and catches open fully, the piston rods must reach their final positions!!** The flow of oil in the piston rods is purposely choked by jets and thus it is not necessary to set a large flow of oil in the tractor.

If the field is raised in the place of the supporting wheels and the wheels do not unfold fully, it is possible to raise the pole of the machine by the supporting leg with the use of hydraulic **circuit C = pressurise the circuit branch designated by one black ring**.

Fig.9 – Auxiliary wheels are in the transport position



Fig.10 – Auxiliary wheels are prepared for unfolding



### 7.4 UNFOLDING THE MACHINE – PHASE 2 – OPENING AND TIPPING

When the process of unfolding the wheels and the bolts has been completed, start with **Circuit A = pressurising the circuit branch designated by one red ring** for opening the side frames from the chassis. Firstly, the side frames will open to the sides and then the whole working section will unfold onto the ground. The flow in the main folding piston is purposely choked by a  $\varnothing 2$  mm jet, so it is not necessary to set a large oil flow in the tractor.

### 7.5 UNFOLDING MACHINE K1570 – PHASE 2 - OPENING+TIPPING

When the process of unfolding the wheels and bolts has been completed, start with **Circuit A = pressurising the circuit branch designated by one red ring** for opening the side frames from the chassis. Firstly, the side frames will open to the sides (see Fig. 11). When the side frames controlled by Circuit A are open so that there is no risk of mechanical collision when opening the external 1.5-meter frames, start with **Circuit D = pressurising the circuit branch designated by one yellow ring** for unfolding the external 1.5-meter frames. If needed, the control of Hydraulic Circuit A may be interrupted until the external 1.5-meter frames have opened into the end position. Then, continue with **Circuit A = pressurising the circuit branch designated by one red ring** for finishing the tipping of the entire work section on the ground. The flow in the main piston of Circuit A is purposely choked by a  $\varnothing 2$  mm jet, so it is not necessary to set a large oil flow in the tractor.



Fig.11 – The side frames are being unfolded

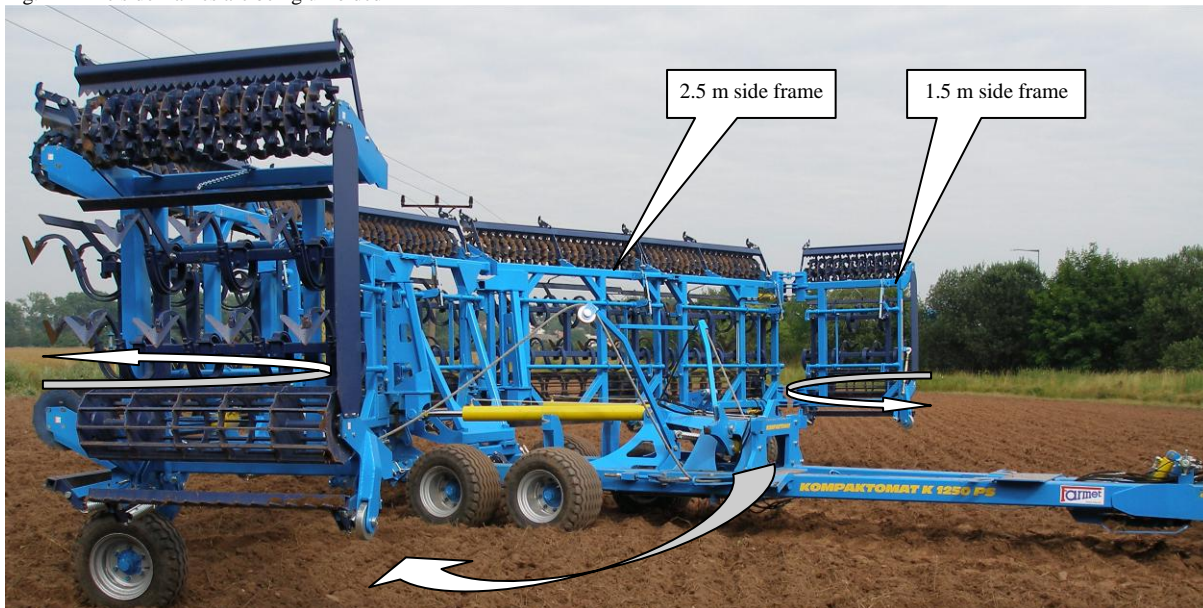


Fig.12 – Tipping the working section into the working position

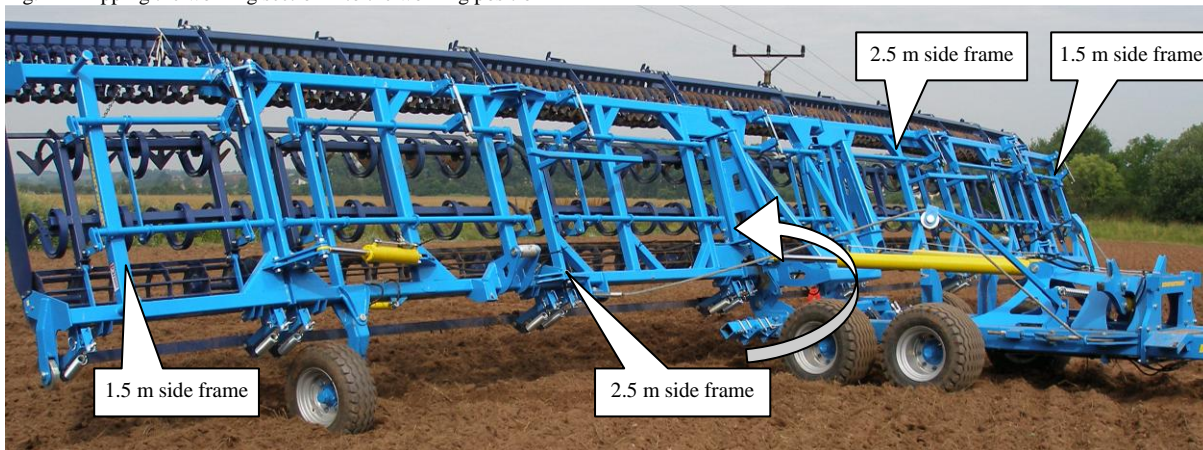


Fig.13 – Tipping the working section into the working position



When **UNFOLDING THE MACHINE PHASE 2** has been completed, i.e. the working section is unfolded and resting on the ground, you must set **Circuit A** into **floating position**. This will prevent the transfer of the chassis weight on the working section, or vice versa.

## 7.6 TRACK CULTIVATORS IN THE WORKING POSITION

Set the track cultivators in the working position after the machine has been unfolded into the working position. Start with **Circuit E = pressurising the circuit branch designated with one yellow and one green ring** for drawing out the piston to its end position.



*Always perform this action on soft surface, not on concrete, asphalt or pavement as that could damage the cultivators or the surface.*

## 8. PROCEDURE FOR FOLDING INTO THE TRANSPORT POSITION

	K1250PS	K1570PS
	1.	1.
	2.	2.

m11690

### 8.1 TRACK CULTIVATORS IN THE TRANSPORT POSITION

Set the track cultivators for the transport position prior to folding the machine to the transport position. Start with **Circuit E = pressurising of the circuit branch designated by one red and one blue ring** for retracting the piston to the end position.

### 8.2 FOLDING MACHINE K1250 – PHASE 1 - TIPPING+CLOSING

Start with **Circuit A = pressurising the circuit branch designated by two red rings** for folding the working section of the machine so that the central frame is resting on the backstop on the chassis. Then continue until the side frames are folded to the chassis. The folded frames must be resting on the prepared bolts on the chassis. When both folded frames are resting on the bolts, turn off the hydraulic circuit.

The flow in the main unfolding piston rod is purposely choked by a  $\varnothing 2$  mm jet, so it is not necessary to set a large oil flow in the tractor.

### 8.3 FOLDING MACHINE K1570 – PHASE 1 - TIPPING+CLOSING

Start with **Circuit A = pressurising the circuit branch designated by two red rings** for folding the working section of the machine so that the central frame is resting on the backstop on the chassis. At this moment, it is possible to start closing the external 1.5-meter frames: start with **Circuit D = pressurising the circuit branch designated by two yellow rings**. If needed, the control of Hydraulic Circuit A may be interrupted until the external 1.5-meter frames have closed in the end position. Then, continue until the side frames are closed in the direction to the chassis. The folded frames must be resting on the prepared bolts on the chassis. When both folded frames are resting on the bolts, turn off the hydraulic circuit.

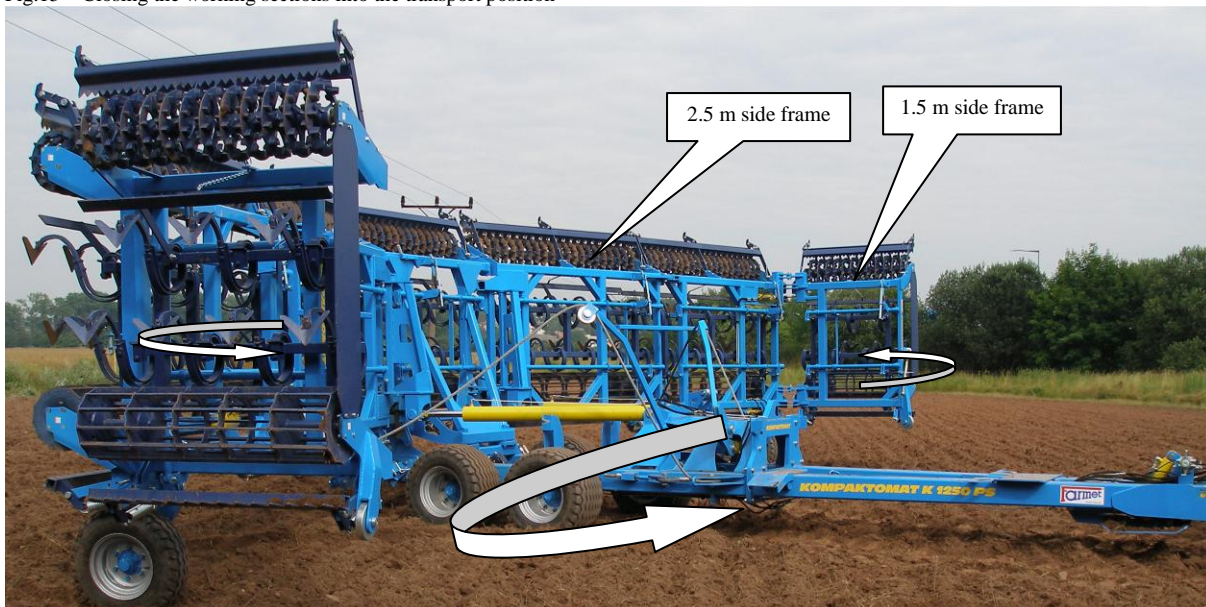
The flow in the main pistons of folding (Circuit A) is purposely choked by  $\varnothing 2$  mm jets, so it is not necessary to set a large oil flow in the tractor.



Fig.14 – The side frames are rising from the ground



Fig.15 – Closing the working sections into the transport position



## 8.4 FOLDING THE MACHINE K1250+K1570 – PHASE 2 – CATCHES AND WHEELS

Start controlling the catches and auxiliary wheels, when the left and right side of the folding working sections reaches the catches. Then start folding by **Circuit B = pressurise the circuit branch designated with one white ring**. Firstly, the folded frames of the working sections will be raised with the help of the catches. Then, the auxiliary wheels will be released and automatically tipped into the transport position. Warning: to make the wheels and catches close fully, the piston rods must reach their final positions!! The flow of oil in the piston rods is purposely choked by jets and thus it is not necessary to set a large flow of oil in the tractor.

Fig.16 – The working section has reached the catches located on the chassis





**8.5.** When the machine folds into the transport position, secure the side frames by the connecting rod and place safety shields into the positions for transportation on ground communications.

Fig.17 – Placing the front safety shields



Fig.18 – Placing the rear safety shields



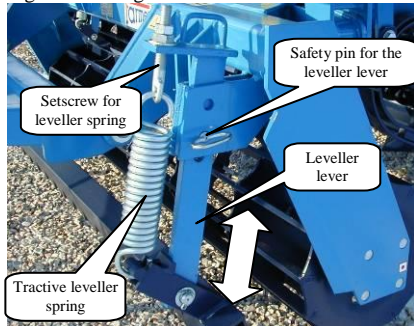
When **FOLDING THE MACHINE PHASE 2** has been completed, i.e. the working section is folded in the transport position, **you must set Circuit A into floating position**. This will prevent the transfer of the undesirable load of the side frames onto the pistons of Circuit A and potential damage incurred during transportation.

## **9. SETTING THE WORKING TOOLS**

### **9.1 ADJUSTING HEIGHT “V” OF THE FRONT LEVELLER (see Fig. 19)**

The front leveller is adjusted by tapping the “PIN” and moving the “LEVER”. The height setting of the front leveller changes according to the size of clods. The leveller is set so that it is about 3 to 5 cm from the lower level of the front bar roller when the machine is lowered on the ground. The springing of the front leveller is provided by a tractive spring which is stretched by the “SETSCREW”. The preload of the spring is selected according to the type of field (according to the size of clods in the field). The larger the clods are, the larger the preload is.

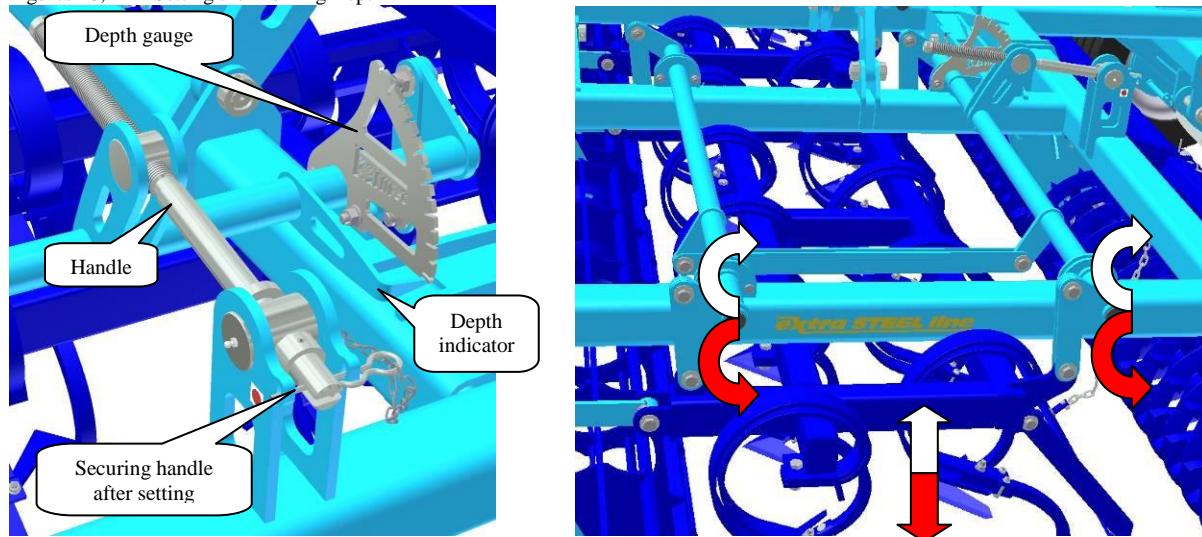
Fig.19 – Setting the rear leveller



### **9.2 SETTING THE “Y” DEPTH OF THE DUCKFOOT-SHARE SECTION (See Fig. 20, 21)**

The working depth of the duckfoot-share section is to be set with a trapezoid-threaded handle. The handle is placed on the supporting frame. To set the depth turn the handle. For an even setting of the depth along the entire machine, a depth setting indicator is located on the handle. The soil processing depth is selected according to the crop type that you want to cultivate, see Tabl. 4.

Figures 20, 21 – Setting the Working Depth



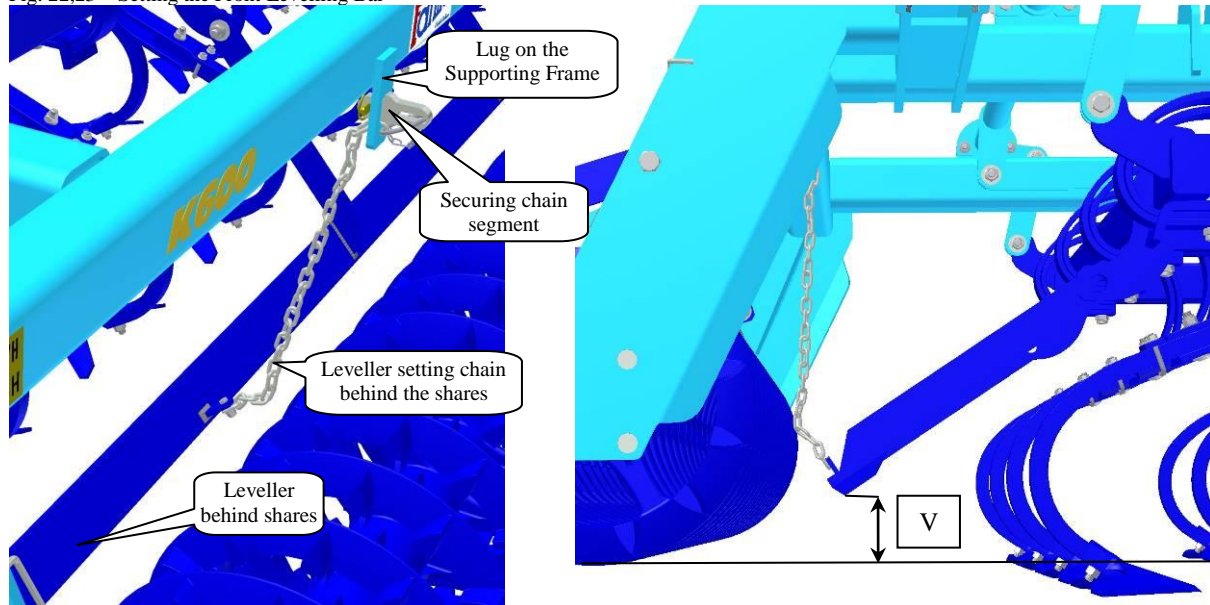
Tabl.4– Informative Working Depths Depending on the Crop

CROP	DEPTH
Beet	2-3 cm
Wheat, Barley, Oats	5-8 cm
Rape	3-5 cm

### 9.3 SETTING THE "Z" HEIGHT OF THE CENTRAL LEVELLING BAR (See Fig. 22,23)

The height of the central levelling bar is to be adjusted using the chain between the sliding and supporting frames depending on the working depth of the duckfoot shares. The chain screwed on the central levelling bar should be hooked up in the lug on the supporting frame. The height should be within the range from 60 to 100 mm (measured from the bottom level of the bar rollers).

Fig. 22,23 – Setting the Front Levelling Bar



### 9.4 PRE-STRESSING TRACTIVE ROPES

Draw the tractive ropes so that they are curved by about 40 mm up from the imaginary plain by lifting pulleys when the machine is unfolded and standing still.



Fig.24 – Prestressing of the tractive rope

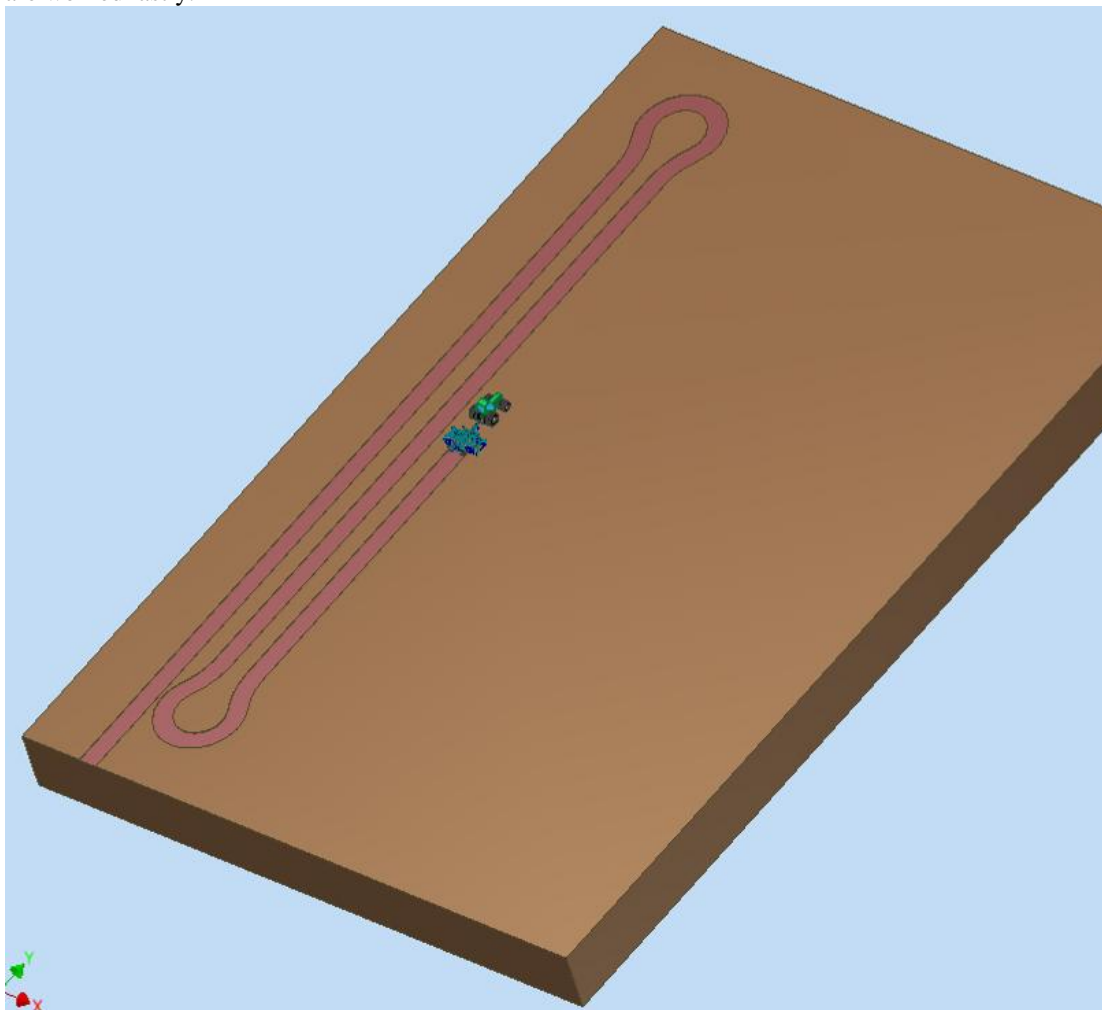


## 10. FIELD WORK POSSIBILITIES FOR THE MACHINE

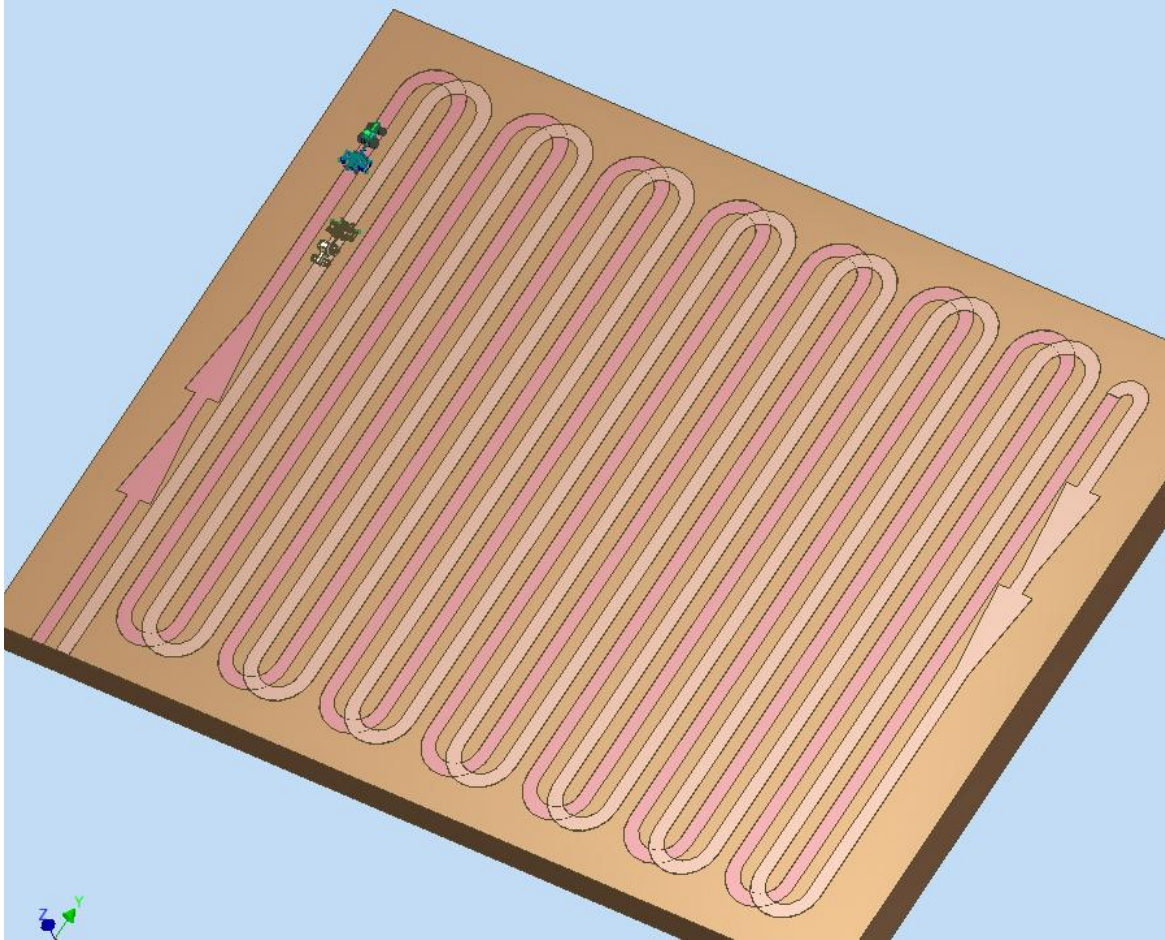
### TURNING AT PLOUGH TURNING END

When working, it is not required to lift or shallow the machine at plough turning ends. However, always turn the machine in adequate curves so that the rear part of the working section located in the internal side of the turning curve does not reverse.

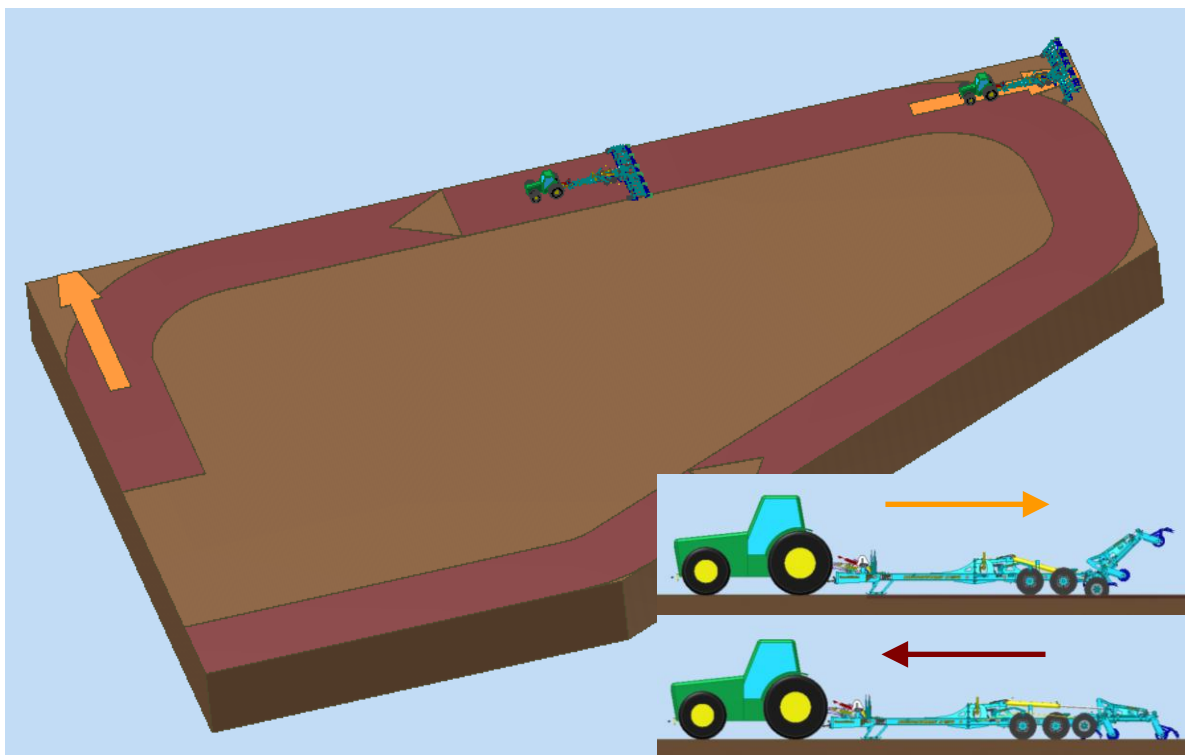
Working without the GPS navigation. Turns are executed without lifting the machine and plough turning ends are worked lastly.



Working with the use of GPS navigation. Turns at the plough turning ends may be larger.



Working on the plough turning end and corners of the land. When reversing, raise the working section by about 45°.





## 11. BRAKE DISTRIBUTION OF THE MACHINE

11.1 The machine is standardly equipped with a single-circuit two-hose brake system by KNORR BREMSE.

11.2 The rear axle of the chassis is equipped by an automatic hand brake.

Fig.25 – Spring brake piston rod for hand brake



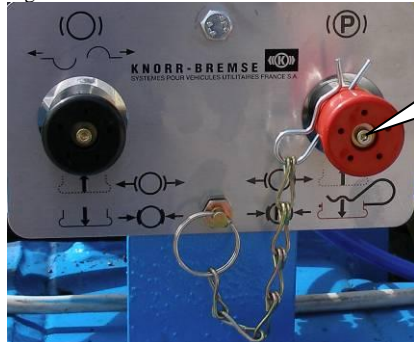
Fig.26 – Hand brake valve control



Fig.27 – Quick coupler for brakes



Fig. 28 – Detail of the brake valve control description



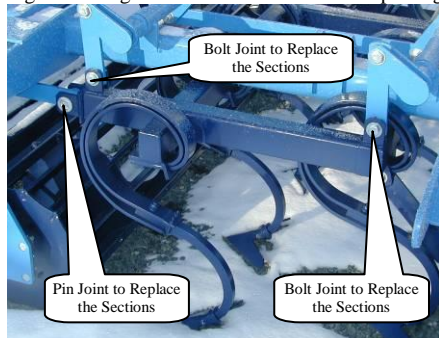
Button for hand brake control  
**RED BUTTON PUSHED IN** = hand brake is not functional  
**RED BUTTON PULLED OUT** = hand brake is activated

## 12. EXCHANGING THE WORKING TOOLS

12.1 When exchanging the working tools, follow the directions given in Chapter L/Page 8. Strictly adhere the prescribed procedure.

12.2 The machine design enables operator to replace the duckfoot shares with a drag by chisel-shaped shares and vice versa. To replace them, drive out the pull-rod pins, remove the original duckfoot shares and fix the new sections (See Fig. 29).

Fig. 29 – Diagram of Joints Intended for Replacing the Share Sections



12.3 The machine design enables operators to replace the rear bar rollers with drags by the Crosskill rollers and vice versa. To replace the rollers, dismount the bearings from the supporting frames of the machine, pull them down from the shafts of the original roller and put them on the new roller. The new roller provided with the bearings must then be mounted in the supporting frames.

12.4 All and any replacements of the working tools should be made in a service shop and all the labour-protection rules mentioned in Chapters C (Page 5), K (Page 8) and L (Page 8) should be strictly observed.

## 13. MAINTENANCE AND REPAIRS

- When making any repairs, strictly observe the labour-protection rules mentioned in Chapters A through N / Pages 4 through 11.
- After first 20 hours and before each use, check that all screw and other assembly joints are tightened well.
- Lubricate the machine in the lubrication points according to the lubrication chart.

- Check the wear and tear of the working tools from time to time. If worn and torn excessively, replace them by new ones.
- Setting, cleaning and lubricating operations may only be carried out at rest. The tractor engine must be turned off and secured against starting.
- If the work is to be done on the lifted machine, suitable supports placed in marked points or other suitable points must be used.
- When setting, maintaining or repairing the machine, secure reliably those parts of the machine that could cause accidents by falling or moving.
- If hoisted with a suspension lifting mechanism (a crane), hang the machine in the marked points only. These points are marked with the "chain".
- Replace the worn ploughshares either when the machine is folded into the transport position or directly in the field, if necessary. For that you need to tip the working section so that it rests on the auxiliary wheels (see Fig. 30, 31),

Fig. 30 – Transport position for ploughshare replacement



Fig.31 – Working section for ploughshare replacement in the field



The section must be supported to prevent an unprompted fall during any manipulation or repair

- When a defect or damage appears, turn off the tractor engine immediately, secure it against undesired start up and motion. Only then can you start to repair it.
- Use solely the original spare parts for repairs. Use the appropriate tools and protectives.
- If you are about to arc-weld and if the machine is coupled with the tractor, disconnect the alternator and accumulator feeding cables.
- Check tire pressure and tire condition regularly. Tire repairs and replacements should be made in a specialized workshop.
- Keep the machine clean.

## 14. LUBRICATION CHART

Tab. 7 - Lubrication points and lubrication intervals

LUBRICATION POINT		INTERVAL	LUBRICANT
Control Handle	Fig.32	<b>- Daily</b> <b>- Before starting the work with the machine</b> <b>- After finishing the work with the machine before shutting it down</b> <b>- Keep required lubrication interval.</b>	-Plastic lubricant -*Plastic lubricant based on lithium
Roller bearings *	Fig.33		
Piston rod bearings location	Fig.34		
Pins, Journals			

Fig.32-Control Handle

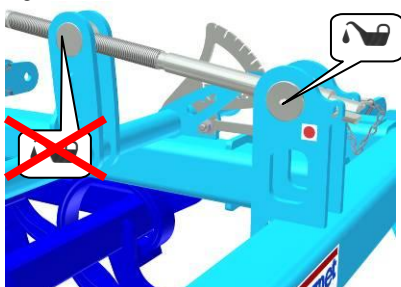
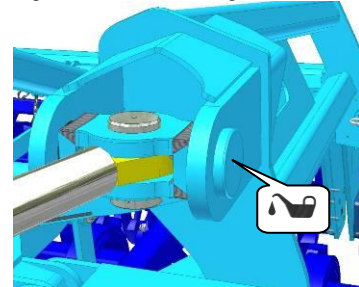


Fig.33 – Roller bearings



Fig.34- Piston rod bearings location



## **15. ENVIRONMENTAL PROTECTION**

- Check tightness of the hydraulic system regularly.
- All the hydraulic hoses and the other parts of the hydraulic system showing signs of damage should be replaced or repaired.
- Remember that the service life of the hydraulic hoses includes their storage time before they were used.
- Dispose the used lubricants according to the related regulations.

## **16. MACHINE DISPOSAL AFTER ITS SERVICE LIFE**

When disposing the machine follow the instructions given under M/Page 8.

## **17. SERVICES AND WARRANTY CONDITIONS**

### **17.1 SERVICES**

After-sale service is ensured by the sales representative after consultation with the manufacturer or directly by the manufacturer. Spare parts are supplied by individual sellers via the nationwide sales network. Spare parts should be ordered according to the official spare-part catalogue issued by the manufacturer.

### **17.2 WARRANTY**

- 17.2.1** The manufacturer gives a 24-month warranty for the following machine parts: The main frame, the axle and the shaft (tow bar). The warranty period for the other parts of the machine is 12 months. The warranty period starts on the date of sale of a new machine to the end user.
- 17.2.2** The warranty applies to hidden defects that become evident within the warranty period provided that the machine has been properly used and maintained according to the Operating manual.
- 17.2.3** The warranty does not apply to common mechanical wear and tear of the exchangeable parts (e.g. shares, blades etc.)
- 17.2.4** The warranty does not apply to indirect consequences (such as a lower service life, etc.) resulting from a possible damage.
- 17.2.5** The warranty is engaged on the particular machine and does not become extinct with changing the owner.
- 17.2.6** The warranty is limited to dismantling and assembling or possibly to replacement or repair to the given defective part. The decision on replacing or repairing the defective part is the sole responsibility of the workshop authorized by Farmet.
- 17.2.7** For the time of the warranty period, only an authorised servicing technician of the producer may perform repairs or other interventions into the machine. Otherwise the warranty will not be acknowledged. This provision does not apply to the replacement of wearable spare parts (see point 17.2.3).
- 17.2.8** The warranty is conditioned by using original spare parts of the manufacturer.

SERVICE MANUAL FOR MACHINE TRANSPORT AXLES  
(take over from the company of ADR SYSTEM s.r.o.)



**A.D.R.** S.p.A.

fabbrica assali  
Via a.m Ceriani N° 96  
21040 uboldo (Varese) Italy  
Tel. 0039-02-961711  
Fax. 0039-02-96171420  
e-mail : rnegrisolo@adraxles.com



UNI EN ISO 9001

**MAINTENANCE MANUAL**

**AXLE TYPES: VALID FOR ALL AXLES BUILT BY OUR COMPANY**

**MAINTENANCE**

The daily maintenance can be done by the user.

Repairs and the change of worn out parts, accident damages, etc. should be carried out by ADR or by a specialist garage.

On the following pages you will find arranged tables of lubrication- and maintenance instructions in mentioned intervals.

**MAINTENANCE PROGRAM**

<b>ART OF OPERATION</b>	<b>km</b>	<b>Week</b>
NORMAL USE	A= 5000	2
LONG DISTANCES	B= 25000 C= 50000 D=100000	4 10 52
HEAVY DUTY USE	A= 3000	2
USE BY LOW TEMPERATURES	B= 15000	3
STATIONARY USE	C= 30000	8
OFF ROAD USE	D= 60000	15
LIGHT USE SPECIAL MACHINES	3 MONTH	
AFTER REPAIR	E= 50 F= 500	



## MAINTENANCE INSTRUCTIONS

### OVERVIEW MAINTENANCE:

#### IDENTIFICATION:

**L = LUBRICATION SERVICE**

**M= MAINTENANCE WORK**

<b>PART NO.</b>	<b>INDICATION</b>	<b>WORKING STEPS</b>	<b>COMMENT</b>	<b>PROGRAM</b>
3 – 3A	NEEDELBEARING	L NEW LUBRICATION	LITHIUM EP GREASE	D
28	CAMSHAFT	L GREASE NIPPEL	CALCIUM GREASE	C
28A	BRAKESHAFT BEARINGS	L GREASE NIPPEL	-	F/B
=====				
3 – 3A	NEEDELBEARING	M BEARING PLAY	ACCORDING TO MANUFACTURER	F/B
15	WHEEL NUTS WHEEL SREWS	M TIGHTENING TORQUE	-	E
	BRAKE	M BRAKE LININGS WEAR OF THE DRUM AND CHECKING THE SEALS	-	C
F/A	BRAKE	M AIR GAP ABOVE THE BRAKE LININGS	ACCORDING TO MANUFACTURER	
40	BRAKE LEVER	M WAY OF THE LEVER	-	F/B
=====				

## **L - LUBRICATION**

### **LUBRICATION OF THE HUB**

Dismantle the hub.

Carfully clean the hub in and outside.

Carfully clean both bearings and afterwards control them.

Renew the grease seal.

Lubricate both bearings with 10 mm thick lithium grease in the quality EPZ.

After mounting and adjusting the bearing play, fill the hub cap to  $\frac{3}{4}$  with grease and tighten it.

### **CAMSHAFT AND CAMSHAFTBEARING**

Camshaft and camshaftbearing have to be lubricated with water resistant calcium grease.

## **M - MAINTENANCE**

For the maintenance please look at the intervals of this maintenance instruction.

### **CONTROL THE BEARING PLAY**

Lift the axle until the tyres no longer touch the ground. Check the bearing play through shaking the wheel.

### **ADJUSTING THE BEARING PLAY**

To adjust the bearing play you have to dismantle the hub cap (21), the pin has to be removed (20), afterwards tighten the axle nut until you feel resistance. Then release the crownnut until the first bore hole fits for the pin.

Secure the pin through bending, fill the hub cap with new grease ( $\frac{3}{4}$ ) and tighten it.

\*\* If there is rust on the hub you have necessarily to lubricate the contact surface with the recommendet type of oil – “PTFE”.

### **WHEEL MOUNTING, TIGHTENING TORQUE OF THE WHEEL SCREWS**

The wheels will be mounted through tightening the wheel screws which are opposite each other. You have necessarily to use a torque wrench.

On the chart below you can see the tightening torque you have to use.

WHEELSCREWS / NUTS	TORQUEMOMENT (da Nm)
M10X1.5	4
M12X1.5	7
M14X1.5	13
M16X1.5	20
M18X1.5	27
M20X1.5	35
M22X1.5	45
M22X2.0	43
M24X1.5	55

### **ADJUSTING THE BRAKE**

#### **ELEVATION OF THE BRAKECYLINDER**

Move the lever in driving direction, the way should be 1/10 of the length of the lever;  
i.g. : with a lever of 180 mm length the way should be 18/21 mm.

If this elevation is too big, the lever has to be adjusted in the following way –  
the lever has to be sat back for one or more theeth on the camshaft.

Farmet a. s.  
Jiřinková 276  
ČESKÁ SKALICE 552 03



Tel.: 00420 491 45 01 40  
491 45 01 22  
Fax.: 00420 491 45 01 36

# LETTER OF GUARANTEE

Machine Model: .....

YEAR OF PRODUCTION/SERIAL NUMBER: \_\_\_\_\_

TECHNICAL INSPECTION: \_\_\_\_\_

BUYER (ADDRESS): \_\_\_\_\_

SELLER (ADDRESS): \_\_\_\_\_

\_\_\_\_\_  
\_\_\_\_\_  
\_\_\_\_\_

\_\_\_\_\_  
\_\_\_\_\_  
\_\_\_\_\_

**WARRANTY:**

- I. The manufacturer gives a 24-month warranty for the following machine parts: The main frame, the axle and the shaft (tow bar). The warranty period for the other parts of the machine is 12 months. The warranty period starts on the date of sale of a new machine to the end user.
- II. The warranty applies to hidden defects that become evident within the warranty period provided that the machine has been properly used and maintained according to the Operating manual.
- III. The warranty does not apply to common mechanical wear and tear of the exchangeable parts (shares, blades, etc.).
- IV. The warranty does not apply to indirect consequences (such as a lower service life, etc.) resulting from a possible damage.
- V. The warranty is engaged on the particular machine and does not become extinct with changing the owner.
- VI. The warranty is limited to dismantling and assembling or possibly to replacement or repair to the given defective part. The decision on replacing or repairing the defective part is the sole responsibility of the workshop authorized by Farmet.
- VII. For the time of the warranty period, only an authorised servicing technician of the producer may perform repairs or other interventions into the machine. Otherwise the warranty will not be acknowledged. This provision does not apply to the replacement of wearable spare parts (see point III).
- VIII. The warranty is conditioned by using original spare parts of the manufacturer.

\_\_\_\_\_  
MANUFACTURER

\_\_\_\_\_  
SELLER

\_\_\_\_\_  
DATE

\_\_\_\_\_  
DATE OF THE FIRST SALE

**ES PROHLÁŠENÍ O SHODĚ**  
**CE CERTIFICATE OF CONFORMITY**  
**EG-KONFORMITÄTSERKLÄRUNG**  
**DÉCLARATION CE DE CONFORMITÉ**  
**СЕРТИФИКАТ СООТВЕТСТВИЯ ЕС**  
**DEKLARACJA ZGODNOŚCI WE**

1. **My** **We** **Wir** **Nous** **Мы** **My**: **Farmet a.s.**  
Jiřínková 276  
552 03 Česká Skalice  
Czech Republic  
DIČ: CZ46504931  
Tel/Fax: 00420 491 450136

**Vydáváme** na vlastní zodpovědnost toto prohlášení. **Hereby issue**, on our responsibility, this Certificate. **Geben** in alleiniger Verantwortung folgende Erklärung ab. **Publions** sous notre propre responsabilité la déclaration suivante. **Под** свою ответственность выдаем настоящий сертификат. **Wydajemy** na własną odpowiedzialność niniejszą Deklarację Zgodności.

2. **Strojní zařízení**: - název : **Polonesený kompaktomat**  
**Machine**: - name : **Semi-Mounted unfolding Kompaktomat**  
**Fabrikat**: - Bezeichnung : **Klappbare Aufsattelgeräte Kompaktomat**  
**Machinerie**: - dénomination : **Compactomats de semi-portage basculants**  
**Сельскохозяйственная машина**: - наименование : **Полунавесной складной компактомат**  
**Urządzenie maszynowe**: - nazwa : **Półzawieszony opruszczany Kompaktomat**  
  
- typ, type : **K 1250 PS**  
- model, modèle : **K 1250 PS II.**  
- **výrobní číslo** :   
- **serial number**  
- **Fabriknummer**  
- **n° de production**  
- **заводской номер**  
- **numer produkcyjny**


3. **Príslušná nařízení vlády**: č.176/2008 Sb. (směrnice 2006/42/ES). **Applicable Governmental Decrees and Orders**: No.176/2008 Sb. (Directive 2006/42/ES). **Einschlägige Regierungsverordnungen (NV)**: Nr.176/2008 Slg. (Richtlinie 2006/42/ES). **Décrets respectifs du gouvernement**: n°.176/2008 du Code (directive 2006/42/CE). **Соответствующие постановления правительства**: № 176/2008 Сб. (инструкция 2006/42/ES). **Odpowiednie rozporządzenia rządowe**: nr 176/2008 Dz.U. (Dyrektywa 2006/42/WE).

4. **Normy s nimiž byla posouzena shoda**: **Standards used for consideration of conformity**: **Das Produkt wurde gefertigt** in Übereinstimmung mit folgenden Normen: **Normes avec lesquelles la conformité a été évaluée**: **Нормы, на основании** которых производилась сертификация: **Normy, według których została przeprowadzona ocena**: ČSN EN ISO 12100, ČSN EN ISO 4254-1.

**Schválil** **Approve by** dne: 01.06.2012  
**Bewilligen** **Approuvé**  
**Утвердил** **Uchwalil**

V České Skalici dne: 01.06.2012

p. Gavlas Dušan  
technický ředitel  
Technical director

  
**Farmet a.s.**  
Jiřínková 276  
552 03 Česká Skalice  
DIČ CZ46504931  
38

Ing. Karel Žďárský  
generální ředitel společnosti  
General Manager

**ES PROHLÁŠENÍ O SHODĚ**  
**CE CERTIFICATE OF CONFORMITY**  
**EG-KONFORMITÄTSERKLÄRUNG**  
**DÉCLARATION CE DE CONFORMITÉ**  
**СЕРТИФИКАТ СООТВЕТСТВИЯ ЕС**  
**DEKLARACJA ZGODNOŚCI WE**

1. **My** **We** **Wir** **Nous** **Мы** **My**: **Farmet a.s.**  
Jiřínková 276  
552 03 Česká Skalice  
Czech Republic  
DIČ: CZ46504931  
Tel/Fax: 00420 491 450136

**Vydáváme** na vlastní zodpovědnost toto prohlášení. **Hereby issue**, on our responsibility, this Certificate. **Geben** in alleiniger Verantwortung folgende Erklärung ab. **Publions** sous notre propre responsabilité la déclaration suivante. **Под** свою ответственность выдаем настоящий сертификат. **Wydajemy** na własną odpowiedzialność niniejszą Deklarację Zgodności.

2. **Strojní zařízení**: - název : **Polonesený kompaktomat**  
**Machine**: - name : **Semi-Mounted unfolding Kompaktomat**  
**Fabrikat**: - Bezeichnung : **Klappbare Aufsattelgeräte Kompaktomat**  
**Machinerie**: - dénomination : **Compactomats de semi-portage basculants**  
**Сельскохозяйственная машина**: - наименование : **Полунавесной складной компактомат**  
**Urządzenie maszynowe**: - nazwa : **Półzawieszony opruszczany Kompaktomat**  
  
- typ, type : **K 1570 PS**  
- model, modèle : **K 1570 PS II.**  
- **výrobní číslo** :   
- **serial number**  
- **Fabriknummer**  
- **n° de production**  
- **заводской номер**  
- **numer produkcyjny**

3. **Průslušná nařízení vlády**: č.176/2008 Sb. (směrnice 2006/42/ES). **Applicable Governmental Decrees and Orders**: No.176/2008 Sb. (Directive 2006/42/ES). **Einschlägige Regierungsverordnungen (NV)**: Nr.176/2008 Slg. (Richtlinie 2006/42/ES). **Décrets respectifs du gouvernement**: n°.176/2008 du Code (directive 2006/42/CE). **Соответствующие постановления правительства**: № 176/2008 Сб. (инструкция 2006/42/ES). **Odpowiednie rozporządzenia rządowe**: nr 176/2008 Dz.U. (Dyrektywa 2006/42/WE).

4. **Normy s nimiž byla posouzena shoda**: **Standards used for consideration of conformity**: **Das Produkt wurde gefertigt** in Übereinstimmung mit folgenden Normen: **Normes avec lesquelles la conformité a été évaluée**: **Нормы, на основании** которых производилась сертификация: **Normy, według których została przeprowadzona ocena**: ČSN EN ISO 12100, ČSN EN ISO 4254-1.

**Schválil** **Approve by** dne: 01.06.2012  
**Bewilligen** **Approuvé**  
**Утвердил** **Uchwalil**

V České Skalici dne: 01.06.2012

p. Gavlas Dušan  
technický ředitel  
Technical director

  
**Farmet a.s.**  
Jiřínková 276  
552 03 Česká Skalice  
DIČ CZ46504931  
3P

Ing. Karel Žďárský  
generální ředitel společnosti  
General Manager